

Model P213 Piston Flow Meter (Analog) 0.5 cc/min to 1800 cc/min

SPECIFICATIONS

Flow Range	0.5 cc/min to 1800 cc/min
Accuracy (at 3 cP)	± 0.2% of reading over a 200:1 range, or ± 2mV (or 4µA), whichever is greater
Maximum Operating Pressure	3000 psi (210 bar)
Weight	1.0 kg
Recommended Filtration	10 micron
Port Sizes	1/8" NPT, #4 SAE or manifold mount
Fluids	Most non-aqueous, hydrocarbon based fluids



MATERIALS OF CONSTRUCTION

External	Stainless steel, type 303
Wetted	Stainless steel, type 303, type 440C; Cobalt based carbide
O-Rings	Standard: Viton® Optional: Teflon®, Perfluoroelastomer, Neoprene

ANALOG TRANSMITTER

Output Signal	Any range of ± 10V or ± 20mA Linearized and damped with anti-dither protection
Power Supply Requirements	Two Models: 12Vdc @ 90 mA, 24Vdc @ 45 mA
Ambient Operational Range	-40°C to 80°C, Single piece – Two piece to 110°C
Metered Liquid Temp Range (based on 20° ambient)	-40°C to 90°C, Standard model -40°C to 225°C, Two piece high temperature model
Compliance	CE Certified, Ex-proof version available with ATEX/IECEx II 2 G Ex db IIB Tx Gb as well as UL, cUL certification for Class 1, Division 1, Groups C and D, Tx

Model P213 Flow Meter (Analog)

DIMENSIONS (Not to scale)

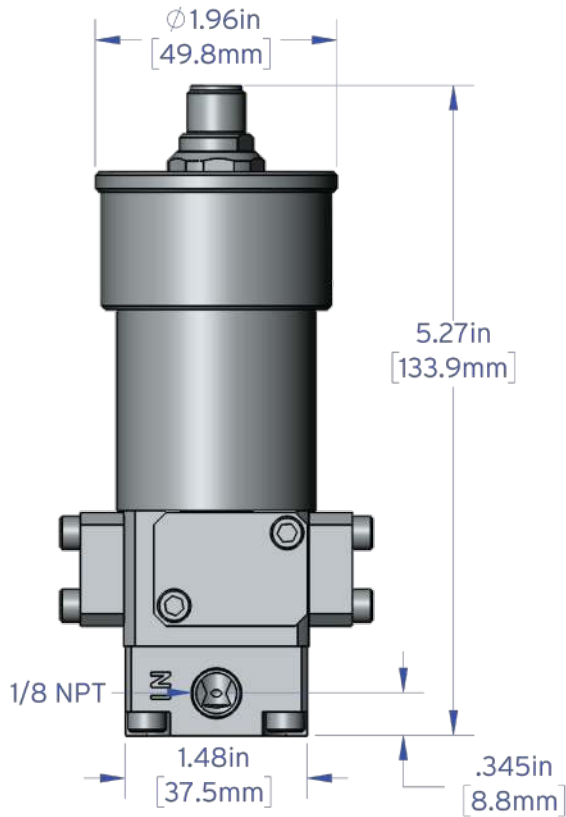

MODEL P213 WITH NPT PORT AND INDUSTRIAL HOUSING

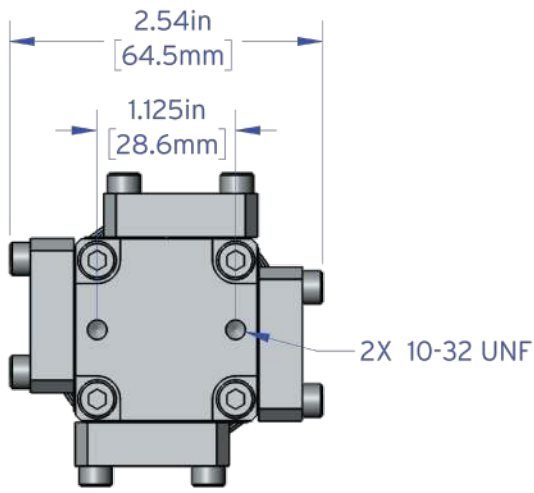

BOTTOM VIEW

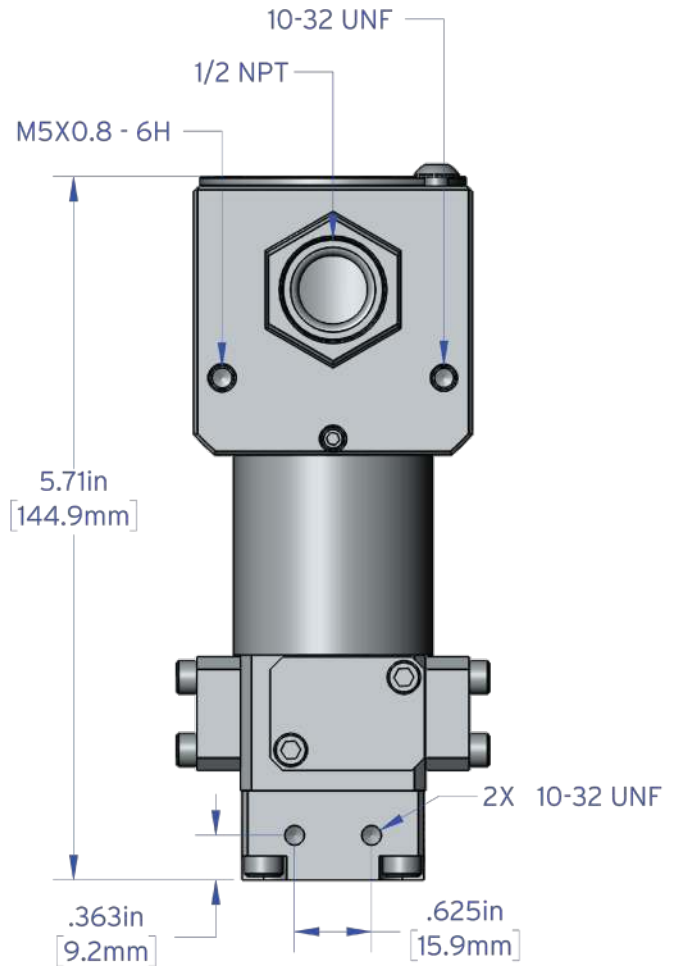
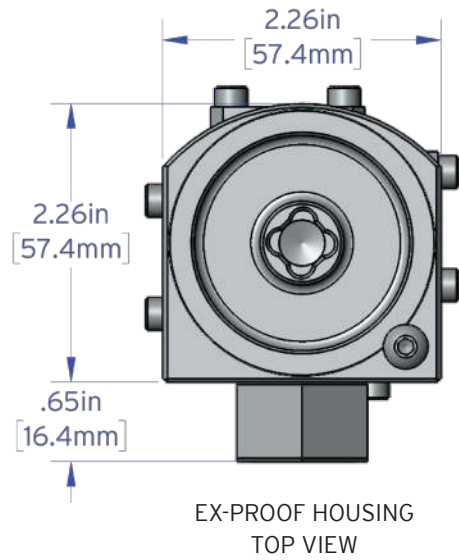

MODEL P213 WITH NPT PORT AND EX-PROOF HOUSING

Model P213 Flow Meter (Analog)

DIMENSIONS (Not to scale)

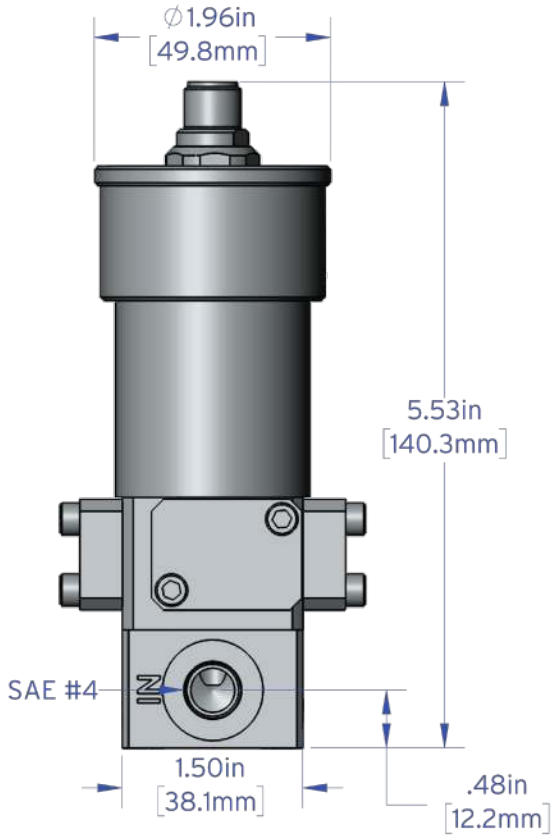

MODEL P213 WITH SAE PORT AND INDUSTRIAL HOUSING

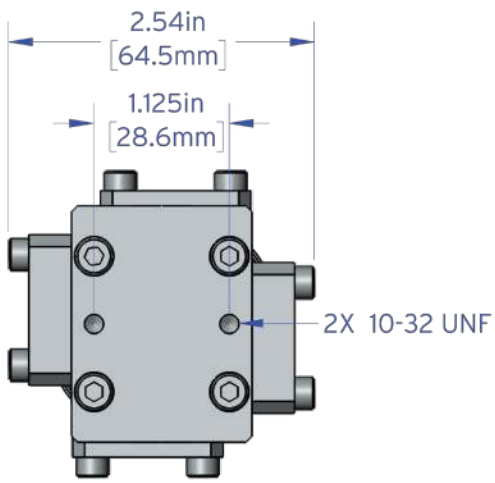

BOTTOM VIEW

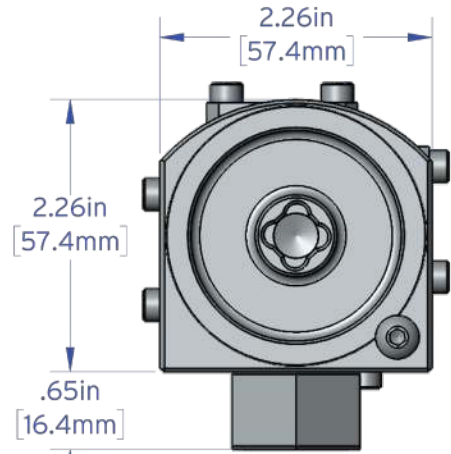

EX-PROOF HOUSING TOP VIEW

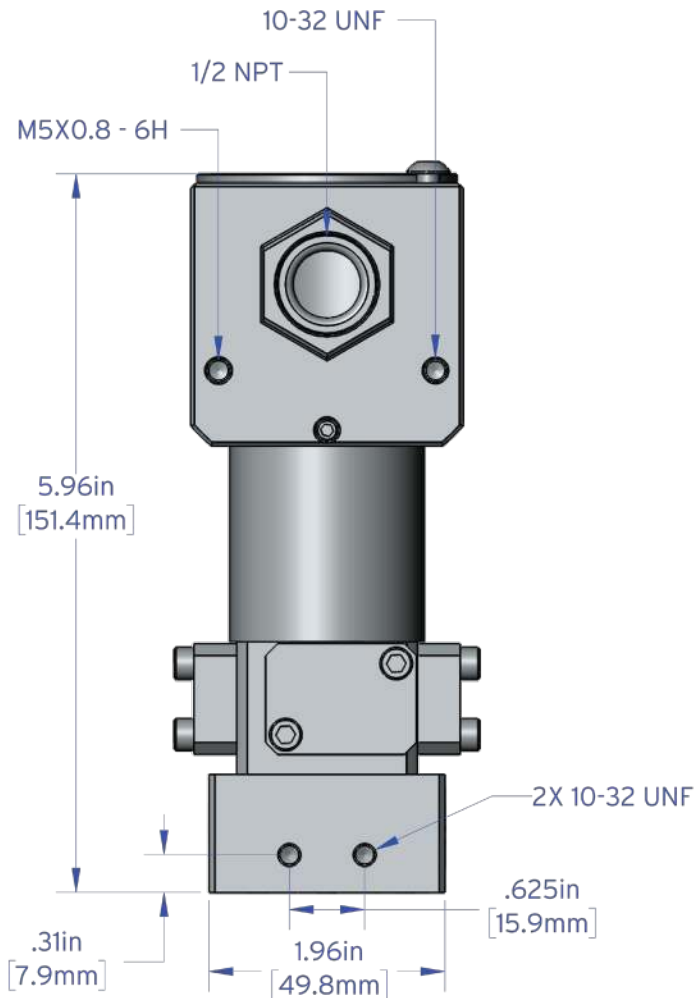

MODEL P213 WITH SAE PORT AND EX-PROOF HOUSING

Model P213 Flow Meter (Analog)

DIMENSIONS (Not to scale)

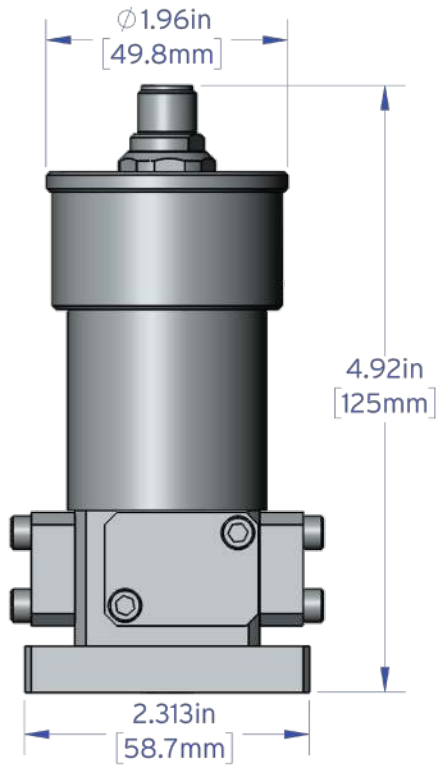

MODEL P213 WITH
MANIFOLD PORT
AND INDUSTRIAL HOUSING

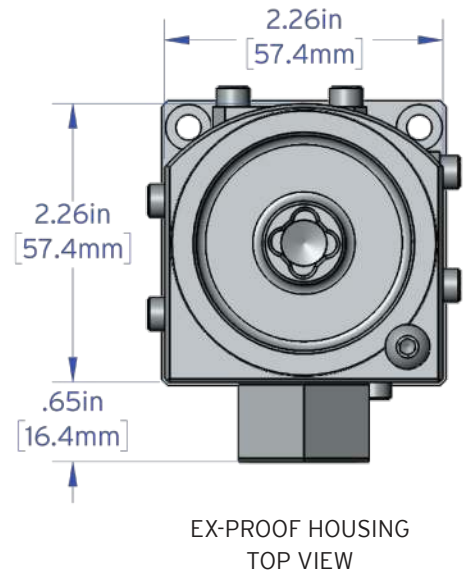

EX-PROOF HOUSING
TOP VIEW

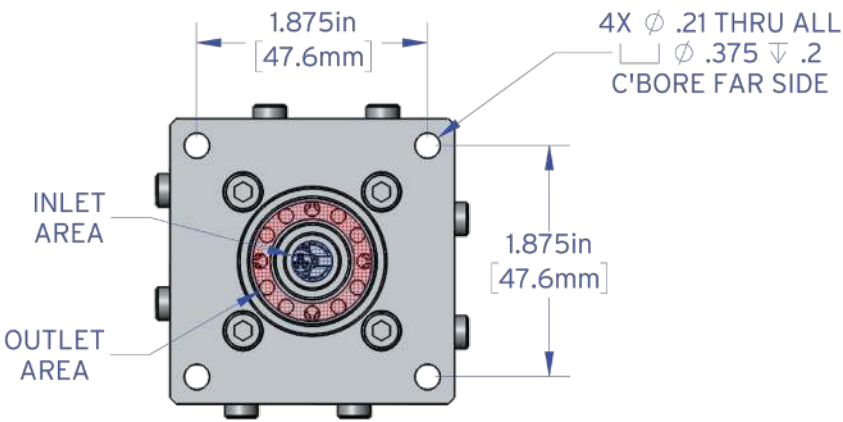

BOTTOM VIEW

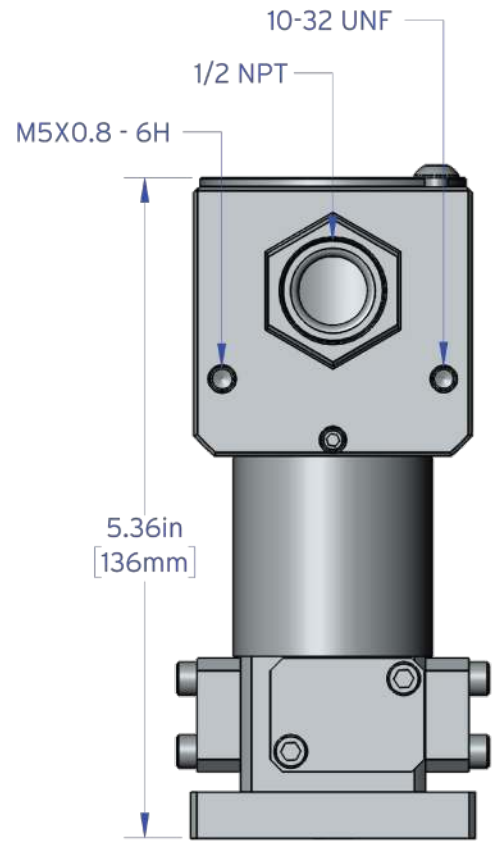

MODEL P213 WITH
MANIFOLD PORT
AND EX-PROOF HOUSING

Model P213 Flow Meter (Analog)

DIMENSIONS (Not to scale)

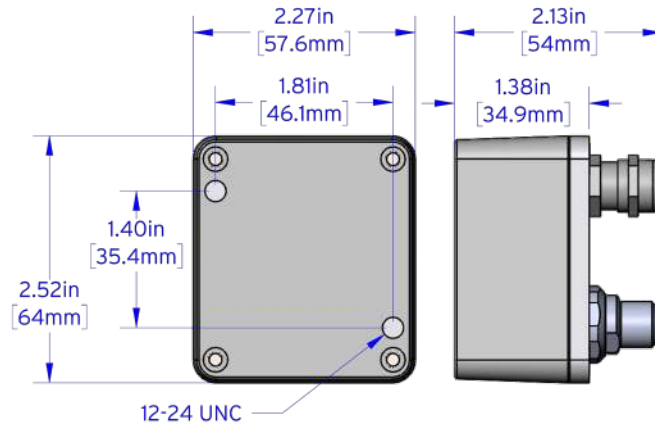

REMOTE PCA ENCLOSURE FOR HIGH TEMPERATURE TRANSMITTERS
 (Not Shown: Industrial 2 meter interconnect cable included, Ex-Proof user supplied interconnect cable required)

CONNECTIVITY

ELECTRICAL CONNECTION – ANALOG TRANSMITTERS

PCA Label	Turck® Connector		
	Pin #	Mating Cable Wire Color	
Power *	V+	1	Brown
Common	Com	4	Black
Signal Output (+)	Sig	5	Grey
Signal Output (-)	Ret	2	White
Case Ground	Case	3	Blue

* Please specify 12Vdc or 24Vdc operation

PRESSURE DROP GRAPH

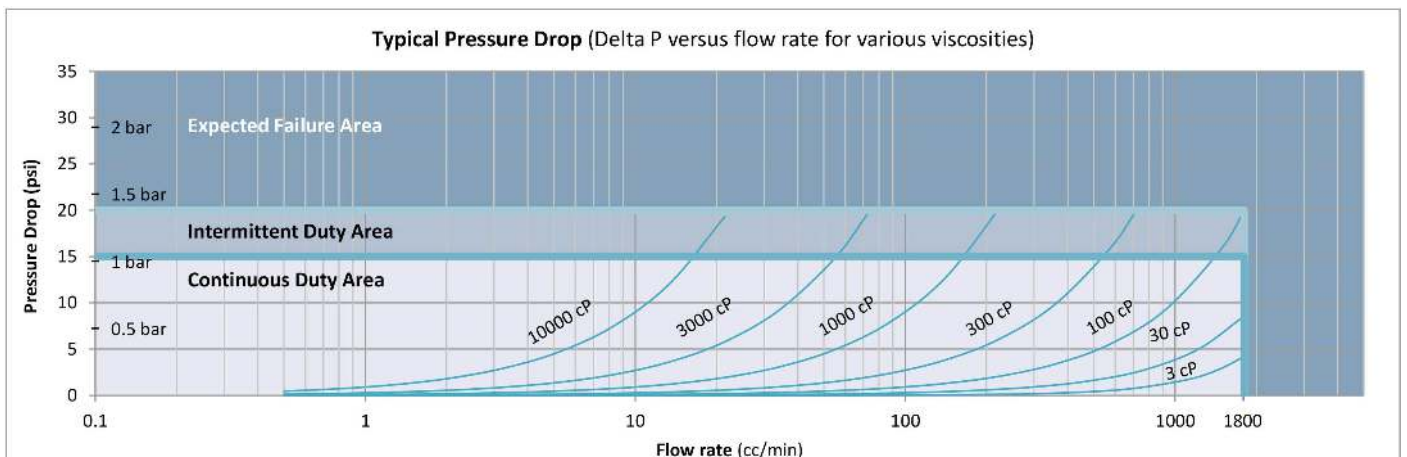

Positive Displacement Flow Meters Piston Type, P-Series 3000 psi (210 bar) rated

Flow Meter Selections Transmitter Selections

Model # MS / / 0 - Non-Standard Options

Bi-Directional Cal: BID

0 Transmitter Type

Max Flow Range

1.8 Liters/Min	P213
10 Liters/Min	P214
35 Liters/Min	P215

Pressure

3000 psi (210 bar) MS

Fluid Connection

NPT	1
SAE	2
Manifold	4
(Not available on model P215)	

Seal Selection

Viton® - FKM	1
Teflon® - PTFE	3
Perfluoroelastomer - FFKM	5
Neoprene	7

Options

None	NA
Heat Trace Option	HT

A
A
A
A
P
Q
P

Output Type

A	4-20mA Output - Powered by 24 Vdc
B	4-20mA Output - Powered by 12 Vdc
C	0-10 Volt Output - Powered by 24 Vdc
D	0-10 Volt Output - Powered by 12 Vdc
N	5V Pulse/Freq. - Powered by 5-26 Vdc
N	5V Quadrature - Powered by 5-26 Vdc
S	Current Sinking, Single Phase

Temperature Rating

1	90°C Industrial / 75°C Haz-Loc
2	130°C Haz-Loc, 2 Part **
3	225°C Industrial, 2 Part †

Electrical Connection

1	Industrial, Turck® Connector
2	Hazardous Location, 1/2 Inch Conduit*

Signal Type

P	Pulse
A	Analog
Q	Quadrature



* See temp chart in product manual.
** Receiver portion of 2 part transmitters are not rated Ex-Proof, consult factory.

† Not available for hazardous location use. (Exceeds 130°C temp. Limit.)
Product includes single directional calibration, bi-directional calibrations for Analog and Quadrature devices are optional.